

ISOLATING VALVES
SEWAGE
 DN 450 to 500



06/17/2022

RASRV28VAG800

Knife Gate Valve DN450-500



The knife gate valve is an ON-OFF gate valve for mudded waters. Its bevelled rectangular shovel, sliding inside a body with a circular outlet as well as its tightness system WEY[®], fit particularly well the transport of mudded fluids.

This valve is used for raw waste waters, mud, water with sediments, in sewage works and sewage pipes under pressure.

Range

The knife gate valve is available from DN50 to DN1200 for a setting between flanges.

DN	PFA	Drilling template
mm	bar	
450-500	4	ISO PN 10

For the other diameters refer to RASRV28VAG700 and RASRV28VAG900

Dimensions and mass

Manual version

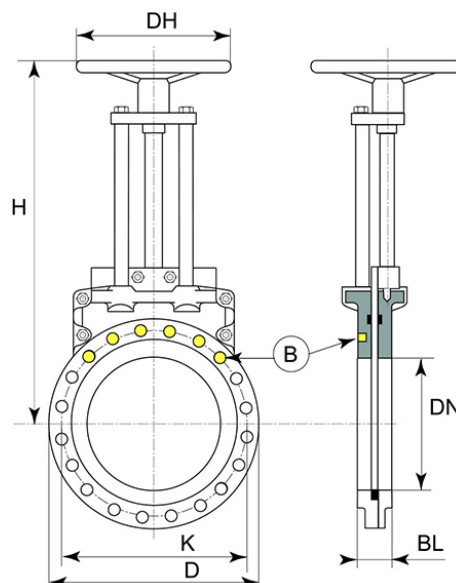

ISOLATING VALVES
SEWAGE
DN 450 to 500



06/17/2022

RASRV28VAG800

DN	D	K	BL	H	Ø hand-wheel	Nb of bolt holes (drilling template)	Mass	References
mm	mm	mm	mm	mm	mm		kg	
450	615	565	114	1112	500	20	210	173312
500	670	620	127	1173	500	20	230	161836

Motorized version

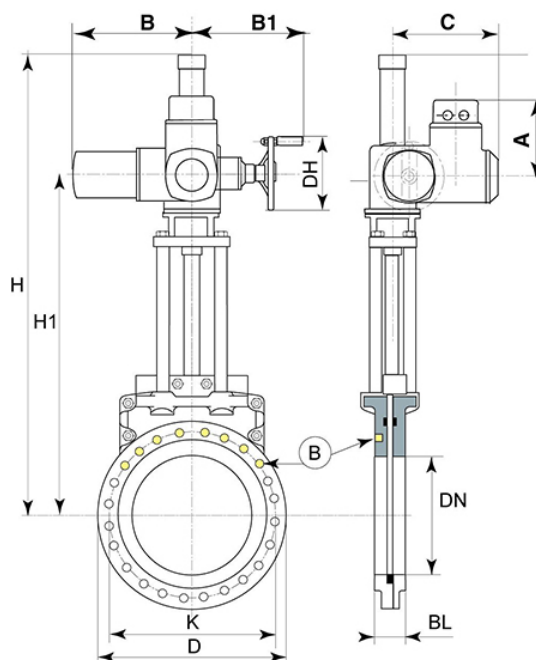

DN	D	K	BL	H	H1	Ø hand-wheel	A	B	B1	C	Servomotor AUMA	Mass	References
mm	mm	mm	mm	mm	mm	mm	mm	mm	mm	mm		kg	
450	615	656	114	1514	1139	315	205	385	320	285	SA 14.1	249	please contact us
500	670	620	127	1675	1200	315	205	385	320	285	SA 14.1	310	please contact us

Dimensional particularity for installation

The bolt holes ref. B are threaded.

The length of the bolts (B) must be adapted to the maximum screw depth on the valve, so that the gate is not blocked.

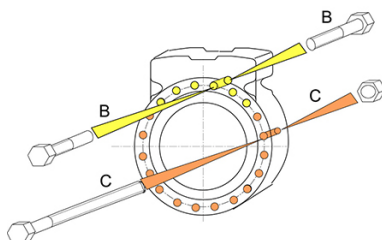

ISOLATING VALVES

SEWAGE

DN 450 to 500



06/17/2022

RASRV28VAG800

DN	Valve assembly				Nbre de boulons par vanne Repère C
	Nb of screwed bolt holes (case B)	Nb of bolts per valve (case B)	Maximum screw depth	Threaded	
450	6	12	14	M 24	14
500	6	12	14	M 24	14

Material and coating

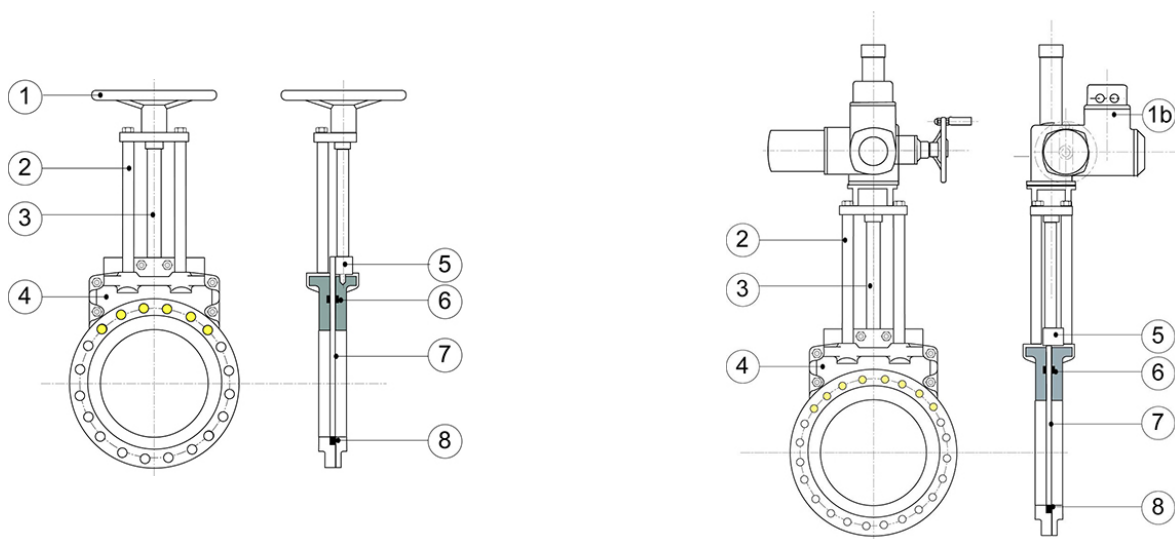

Item	Designation	Material	Coating
1	Hand wheel		Epoxy power average thickness 75µm, grey colour
1b	Actuator Auma		Epoxy power average thickness 75µm, grey colour
2	Column	Steel	Epoxy power average thickness 75µm, grey colour
3	Body	Cast iron Ft 25	Epoxy power average thickness 175µm, grey colour
4	Screw	Steel Type Z13CF17	
5	Operating nut	Bronze	
6	Transversal gasket	Nitrile	
7	Gate	Steel Type Z7CN18.09	
8	Hemispherical Joint	Nitrile	

ISOLATING VALVES

SEWAGE

DN 450 to 500



06/17/2022

RASRV28VAG800

Specificity

Transversal gasket

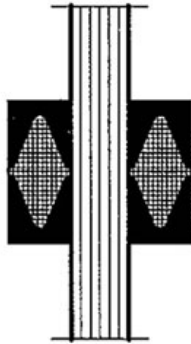

- The transversal gasket is placed on both sides of the gate. This replaceable device prevents leakage along the gate, grants the valve a longer life.

Peripheral gasket

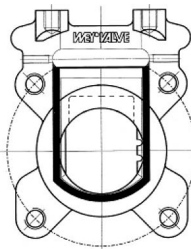

- The peripheral gasket is O'ring type. It guarantees a smooth track for the gate and assuring the body and gate tightness.

Flushing points

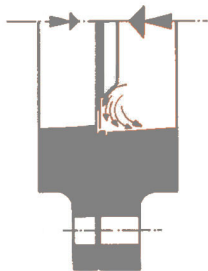

- The gate has a bevelled profile.
- The shape of the body presents flushing points on the closing zone, producing a self cleaning effect and preventing the accumulation of fragments.
- The full bore passage allows the use of all the pipe cleaning technics and provides minimal headloss.

Conformity to Standards

Dimensional

- distance between flanges:
 - ISO 5752
 - NF E 29305-1
 - DIN 3202
- drilling template of flanges:

ISOLATING VALVES SEWAGE DN 450 to 500		06/17/2022
		RASRV28VAG800

- ISO 7005 PN 10-16
- NF E 29206
- DIN 2532

Operating stem under frame, according to the regulation on personnel security.

Functional

- tightness test on every valve to 1.1 PFA according to:
 - ISO 5208
 - NF E 29311
 - DIN 3230 Part 3

Marking

A marking of foundry is present on the body. The indication PN10 or PN16 refers to the drilling template whereas PB 4 or PB 6 corresponds to PFA 4 or 6 bars.

An identification plate PAM S.A. indicates the type, the serial number, the DN as well as the PN.

Accessories

The gate valve can be equipped with a contactor that stops the flow.

Setting, servicing, maintenance

- Assembly direction: place the bevelled part of the gate upstream.
- The knife valve is integrated between flanges. Provide the self-restrained dismantling joint type PF and flange gaskets.
Note: for the setting, see absolutely that screws respect the maximum screwing depth so as they do not block the gate.
- During the use, it is possible to compress the superior transversal gasket thanks to side screws.